



KONFORMITÄTSNACHWEIS FÜR ERZEUGUNGSEINHEITEN

Hersteller **FRONIUS International GmbH**
Günter Froniusstr. 1, 4600 WELS-THALHEIM
AUSTRIA

Erzeugungseinheit **Netzgekoppelter Photovoltaikwechselrichter**

Typ Erzeugungseinheit	Nennwirkleistung	Nennscheinleistung	Bemessungsspannung
SYMO 10.0-3-M	10.000 W	10.000 VA	3/N/PE AC 400/230 V
SYMO 12.5-3-M	12.500 W	12.500 VA	
SYMO 15.0-3-M	15.000 W	15.000 VA	
SYMO 17.5-3-M	17.500 W	17.500 VA	
SYMO 20.0-3-M	20.000 W	20.000 VA	

Weitere Informationen Siehe Seite 2-15

Firmwareversion SW1: V 0.9.8.3; SW2: V 0.6.10.1

Netzanschlussregel VDE-AR-N 4105:2011-08
Erzeugungsanlagen am Niederspannungsnetz -
Technische Mindestanforderungen für Anschluss und Parallelbetrieb
von Erzeugungsanlagen am Niederspannungsnetz

Prüfgrundlage DIN VDE V 0124-100 (VDE V 0124-100):2012-07
Netzintegration von Erzeugungsanlagen - Niederspannung -
Prüfanforderungen an Erzeugungseinheiten vorgesehen zum
Anschluss und Parallelbetrieb am Niederspannungsnetz

Prüfbericht 222084-CI3-1 vom 2016-03-16

ID Nummer 40038483, Revision 1

Befristet zum 2018-03-17

Dieser Konformitätsnachweis bestätigt, dass die oben bezeichneten Erzeugungseinheiten die Anforderungen der Netzanschlussregel VDE-AR-N 4105:2011-08 und der Norm DIN VDE V 0124-100 (VDE V 0124-100):2012-07 erfüllen.

- Nachweis zulässiger Netzurückwirkungen
- Nachweis des Symmetrieverhaltens von Drehstromumrichter-Einheiten
- Nachweis des Verhaltens der Erzeugungseinheit am Netz

Dieser Konformitätsnachweis beinhaltet folgende Angaben:

- technische Daten der Erzeugungseinheit, der eingesetzten Hilfseinrichtungen und der verwendeten Softwareversion;
- den schematischen Aufbau der Erzeugungseinheit;
- zusammengefasste Angaben zu den Eigenschaften der Erzeugungseinheit (Wirkungsweise).

Dieser Konformitätsnachweis berechtigt nicht zur Nutzung eines markenrechtlich geschützten Zeichens des VDE.

VDE Prüf- und Zertifizierungsinstitut GmbH

VDE Testing and Certification Institute

Zertifizierungsstelle/Certification

M. Tasotti

2016-03-18

Merianstrasse 28, 63069 Offenbach, Germany
phone +49 69 83 06-0, fax: +49 69 83 06-555
e-mail: vde-institut@vde.com, www.vde-institut.com

VDE Zertifikate sind nur gültig bei Veröffentlichung unter: www.vde.com/zertifikat
VDE certificates are valid only when published on: www.vde.com/certificate

VDE
INSTITUT

Beschreibung der Erzeugungseinheit

Hersteller	FRONIUS International GmbH Güter Fronius Straße 1 4600 Wels-Thalheim AUSTRIA		
Typ Erzeugungseinheit	Netzgekoppelter Photovoltaikwechselrichter		
Bemessungswerte	SYMO 15.0-3-M	SYMO 17.5-3-M	SYMO 20.0-3-M
Nennwirkleistung	15000 W	17500 W	20000 W
Nennscheinleistung	15000 VA	17500 VA	20000 VA
Bemessungsspannung	3/N/PE AC 400/230 V		
Firmware Version	SW1: V 0.9.8.3 ; SW2: V 0.6.10.1;		
Messzeitraum	17.02.2014 bis 28.02.2014		

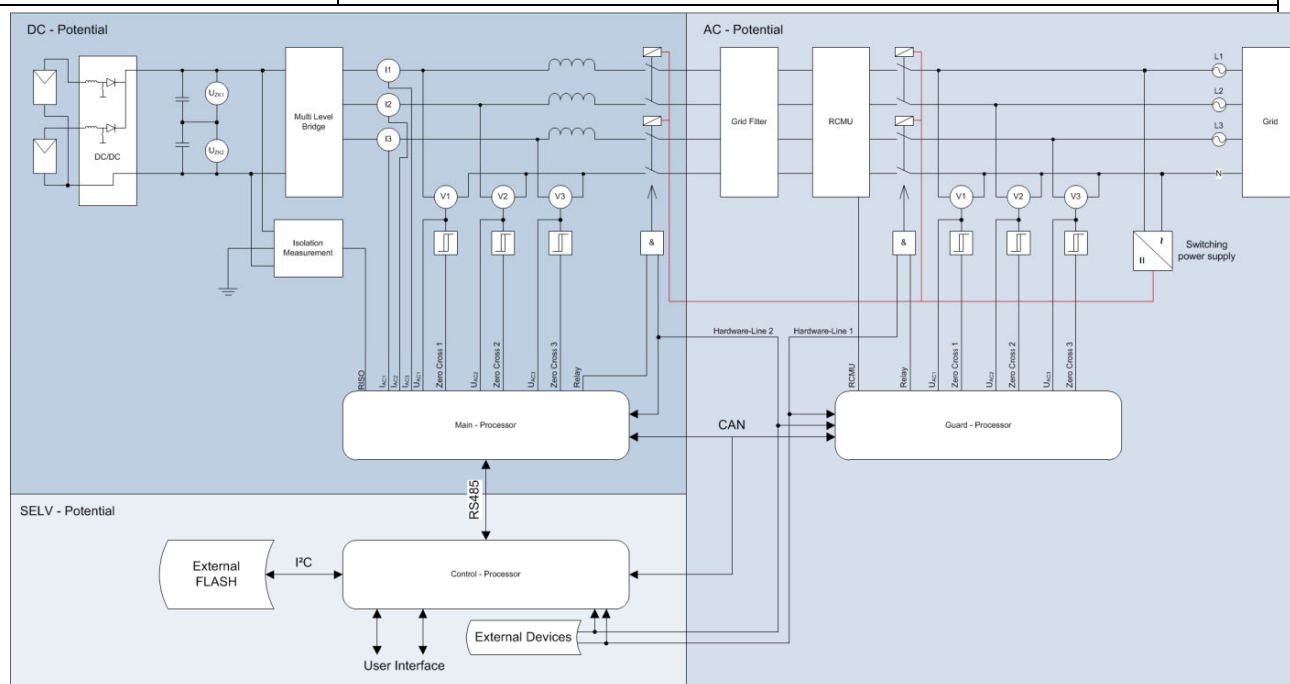
Schematischer Aufbau der Erzeugungseinheit (EZE)

Die Modelle **SYMO 15.0-3-M**, **SYMO 17.5-3-M**, **SYMO 20.0-3-M** sind bezüglich des Erzeugungs- und Einspeiseverhaltens identisch aufgebaut und bilden die Hardware-Variante 2 (Hardware version 2 – big unit). Sie unterscheiden sich nur in der Softwarebegrenzung der maximalen Wirkleistung.

Die Prüfungen wurden am Typ **Fronius SYMO 20.0-3-M** durchgeführt und sind stellvertretend für die Geräte **Fronius SYMO 15.0-3-M, SYMO 17.5-3-M, SYMO 20.0-3-M** gültig.

Wirkleistung; DIN VDE V 0124-100:2012-07; 5.3.2.1

Maximale Wirkleistung $P_{E_{max}}$	-20,506 kW
Maximale Scheinleistung $S_{E_{max}}$	20,599 kVA

Blindleistungsbezug; DIN VDE V 0124-100:2012-07; 5.3.2.1

Wirkleistung P / P _n [%]	10	20	30	40	50	60	70	80	90	100
Maximale möglicher $\cos \varphi$ untererregt	N/A	N/A	N/A	N/A	N/A	N/A	N/A	N/A	N/A	-0,897
Maximale möglicher $\cos \varphi$ übererregt	N/A	N/A	N/A	N/A	N/A	N/A	N/A	N/A	N/A	-0,903

Einhaltung eines fest vorgegeben Verschiebungsfaktor $\cos \varphi$ DIN VDE V 0124-100:2012-07; 5.3.6.1

Vorgabe in der Anlagesteuerung	-0,900 _{üb}	-0,950 _{üb}	-1,000	-0,950 _{un}	-0,900 _{un}
Messwert an den Klemmen der EZE	-0,903	N/A	N/A	N/A	-0,897

Blindleistungsübergangsfunktion – Standard- $\cos \varphi$ (P)-Kennlinie; DIN VDE V 0124-100:2012-07; 5.3.6.4

Wirkleistung P / P _n [%]	10	20	30	40	50	60	70	80	90	100*)
$\cos \varphi$	-1,000	-1,000	-1,000	-1,000	-0,999	-0,980	-0,960	-0,940	-0,921	-0,913

Die Standard- $\cos \varphi$ -(P)-Kennlinie wird eingehalten

*) Wird nicht erreicht da $S_{E_{max}} = 20,0$ kVA

Schalthandlungen; Schnelle Spannungsänderungen; DIN VDE V 0124-100:2012-07; 5.1.2

Einschalten ohne Vorgabe (zum Primärenergieträgers)	k_i	0,44
Ungünstigster Fall	k_i	1,08
Einschalten bei Nennbedingungen (des Primärenergieträgers)	k_i	0,97
Ausschalten bei Nennleistung	k_i	0,97
Schlechtester Wert aller Schaltvorgänge	$k_{i_{max}}$	1,08

Flicker (worst case)	Netzimpedanzwinkel ψ_k :	32°
	Anlagenflickerbeiwert c_{ψ} :	10,09

Oberschwingungsmessungen (Harmonics) nach EN 61000-3-12 und VDE-AR-N 4105:2011-08 Anhang F.3 (Phase L1);								
Harmonic Order	I_H_mean	I_H_max	I_H_mean	(Average/Ref Fund) ²	n*(Average/Ref Fund) ²	I_H_max	Stage 1 Limit (EN 61000-3-12)	PASS/FAIL
	(A)	(A)	(%H01)			(%H01)	∏	∏
1	29.145	29.2459	100.00%			100.00%	Inf%	N/A
2	0.0664	0.2351	0.23%	8.97E-06		0.81%	4.00%	P
3	0.1375	0.188	0.47%	2.25E-05		0.65%	21.60%	P
4	0.0489	0.122	0.17%	3.25E-06		0.42%	2.00%	P
5	0.1991	0.2312	0.68%	4.68E-05		0.79%	10.70%	P
6	0.0228	0.0665	0.08%	7.72E-07		0.23%	1.30%	P
7	0.0368	0.0765	0.13%	1.71E-06		0.26%	7.20%	P
8	0.0141	0.045	0.05%	3.46E-07		0.16%	1.00%	P
9	0.0611	0.0832	0.21%	4.43E-06		0.29%	3.80%	P
10	0.0203	0.0463	0.07%	5.28E-07		0.16%	0.80%	P
11	0.0392	0.0659	0.14%	1.86E-06		0.23%	3.10%	P
12	0.0199	0.0377	0.07%	4.84E-07		0.13%	0.70%	P
13	0.0838	0.0972	0.29%	8.31E-06		0.33%	2.00%	P
14	0.0083	0.0293	0.03%	1.20E-07	1.68E-06	0.10%	Inf%	N/A
15	0.0183	0.0326	0.06%	4.15E-07	6.23E-06	0.11%	Inf%	N/A
16	0.0092	0.0262	0.03%	1.26E-07	2.01E-06	0.09%	Inf%	N/A
17	0.0791	0.0915	0.27%	7.41E-06	1.26E-04	0.31%	Inf%	N/A
18	0.0138	0.026	0.05%	2.33E-07	4.19E-06	0.09%	Inf%	N/A
19	0.0255	0.0363	0.09%	7.75E-07	1.47E-05	0.12%	Inf%	N/A
20	0.0071	0.0239	0.02%	7.96E-08	1.59E-06	0.08%	Inf%	N/A
21	0.0419	0.053	0.14%	2.08E-06	4.37E-05	0.18%	Inf%	N/A
22	0.0054	0.0163	0.02%	4.30E-08	9.47E-07	0.06%	Inf%	N/A
23	0.0352	0.0472	0.12%	1.49E-06	3.42E-05	0.16%	Inf%	N/A
24	0.008	0.0184	0.03%	8.70E-08	2.09E-06	0.06%	Inf%	N/A
25	0.0382	0.0445	0.13%	1.73E-06	4.33E-05	0.15%	Inf%	N/A
26	0.0048	0.0166	0.02%	3.75E-08	9.76E-07	0.06%	Inf%	N/A
27	0.029	0.039	0.10%	1.00E-06	2.70E-05	0.13%	Inf%	N/A
28	0.004	0.013	0.01%	2.65E-08	7.43E-07	0.04%	Inf%	N/A
29	0.0325	0.0405	0.11%	1.26E-06	3.66E-05	0.14%	Inf%	N/A
30	0.0051	0.0146	0.02%	3.86E-08	1.16E-06	0.05%	Inf%	N/A
31	0.0339	0.0402	0.12%	1.36E-06	4.23E-05	0.14%	Inf%	N/A
32	0.0033	0.0136	0.01%	2.09E-08	6.68E-07	0.05%	Inf%	N/A
33	0.0219	0.0285	0.08%	5.74E-07	1.89E-05	0.10%	Inf%	N/A
34	0.0034	0.0123	0.01%	1.92E-08	6.52E-07	0.04%	Inf%	N/A
35	0.0332	0.0386	0.11%	1.30E-06	4.57E-05	0.13%	Inf%	N/A
36	0.0041	0.0117	0.01%	2.47E-08	8.87E-07	0.04%	Inf%	N/A
37	0.0228	0.0291	0.08%	6.17E-07	2.28E-05	0.10%	Inf%	N/A
38	0.0034	0.0129	0.01%	1.84E-08	7.01E-07	0.04%	Inf%	N/A
39	0.0244	0.0299	0.08%	7.08E-07	2.76E-05	0.10%	Inf%	N/A
40	0.003	0.0106	0.01%	1.46E-08	5.82E-07	0.04%	Inf%	N/A
THD(%)				1.10%			23.00%	P
PWHD(%)					2.30%		23.00%	P

Oberschwingungsmessungen (Harmonics) nach EN 61000-3-12 und VDE-AR-N 4105:2011-08 Anhang F.3 (Phase L2);								
Harmonic Order	I _H _{mean}	I _H _{max}	I _H _{mean}	(Average/Ref Fund) ²	n*(Average/Ref Fund) ²	I _H _{max}	Stage 1 Limit (EN 61000-3-12)	PASS/FAIL
	(A)	(A)	(%H01)			(%H01)	∏	∏
1	29.4341	29.5632	100.00%			100.00%	Inf%	N/A
2	0.0498	0.1959	0.17%	5.36E-06		0.66%	4.00%	P
3	0.0519	0.1391	0.18%	3.59E-06		0.47%	21.60%	P
4	0.019	0.086	0.06%	8.09E-07		0.29%	2.00%	P
5	0.1008	0.1297	0.34%	1.18E-05		0.44%	10.70%	P
6	0.0162	0.0495	0.06%	3.73E-07		0.17%	1.30%	P
7	0.0814	0.0939	0.28%	7.67E-06		0.32%	7.20%	P
8	0.0111	0.0388	0.04%	1.97E-07		0.13%	1.00%	P
9	0.0189	0.0401	0.06%	4.42E-07		0.14%	3.80%	P
10	0.0067	0.0315	0.02%	9.71E-08		0.11%	0.80%	P
11	0.0374	0.0572	0.13%	1.63E-06		0.19%	3.10%	P
12	0.0085	0.022	0.03%	9.52E-08		0.08%	0.70%	P
13	0.0415	0.0514	0.14%	2.00E-06		0.17%	2.00%	P
14	0.0106	0.0255	0.04%	1.42E-07	1.99E-06	0.09%	Inf%	N/A
15	0.0214	0.0318	0.07%	5.39E-07	8.09E-06	0.11%	Inf%	N/A
16	0.0076	0.021	0.03%	8.10E-08	1.30E-06	0.07%	Inf%	N/A
17	0.0281	0.0457	0.10%	9.30E-07	1.58E-05	0.16%	Inf%	N/A
18	0.0047	0.0143	0.02%	3.28E-08	5.90E-07	0.05%	Inf%	N/A
19	0.0254	0.0311	0.09%	7.46E-07	1.42E-05	0.11%	Inf%	N/A
20	0.0067	0.0189	0.02%	5.92E-08	1.18E-06	0.06%	Inf%	N/A
21	0.0219	0.0311	0.07%	5.59E-07	1.17E-05	0.11%	Inf%	N/A
22	0.0073	0.0156	0.03%	6.59E-08	1.45E-06	0.05%	Inf%	N/A
23	0.0223	0.0378	0.08%	5.83E-07	1.34E-05	0.13%	Inf%	N/A
24	0.0044	0.0134	0.02%	2.98E-08	7.16E-07	0.05%	Inf%	N/A
25	0.0175	0.0216	0.06%	3.57E-07	8.93E-06	0.07%	Inf%	N/A
26	0.0043	0.014	0.02%	2.62E-08	6.82E-07	0.05%	Inf%	N/A
27	0.0186	0.0271	0.06%	4.06E-07	1.10E-05	0.09%	Inf%	N/A
28	0.0048	0.0112	0.02%	3.00E-08	8.41E-07	0.04%	Inf%	N/A
29	0.0208	0.03	0.07%	5.10E-07	1.48E-05	0.10%	Inf%	N/A
30	0.0038	0.0109	0.01%	2.03E-08	6.08E-07	0.04%	Inf%	N/A
31	0.0127	0.02	0.04%	1.88E-07	5.83E-06	0.07%	Inf%	N/A
32	0.0034	0.0103	0.01%	1.59E-08	5.10E-07	0.04%	Inf%	N/A
33	0.0161	0.0229	0.06%	3.08E-07	1.02E-05	0.08%	Inf%	N/A
34	0.0031	0.0097	0.01%	1.44E-08	4.91E-07	0.03%	Inf%	N/A
35	0.0192	0.0245	0.07%	4.36E-07	1.52E-05	0.08%	Inf%	N/A
36	0.0028	0.0097	0.01%	1.14E-08	4.10E-07	0.03%	Inf%	N/A
37	0.01	0.0197	0.03%	1.22E-07	4.50E-06	0.07%	Inf%	N/A
38	0.0026	0.0089	0.01%	1.02E-08	3.89E-07	0.03%	Inf%	N/A
39	0.0141	0.0194	0.05%	2.34E-07	9.11E-06	0.07%	Inf%	N/A
40	0.0025	0.0078	0.01%	9.31E-09	3.72E-07	0.03%	Inf%	N/A
THD(%)				0.60%			23.00%	P
PWHD(%)					1.20%		23.00%	P

Oberschwingungsmessungen (Harmonics) nach EN 61000-3-12 und VDE-AR-N 4105:2011-08 Anhang F.3 (Phase L3);								
Harmonic Order	I_H_mean	I_H_max	I_H_mean	(Average/Ref Fund) ²	n*(Average/Ref Fund) ²	I_H_max	Stage 1 Limit (EN 61000-3-12)	PASS/FAIL
	(A)	(A)	(%H01)			(%H01)	∞	∞
1	29.4883	29.5789	100.00%			100.00%	Inf%	N/A
2	0.0665	0.199	0.23%	6.29E-06		0.67%	4.00%	P
3	0.0826	0.1141	0.28%	7.93E-06		0.39%	21.60%	P
4	0.0357	0.0856	0.12%	1.63E-06		0.29%	2.00%	P
5	0.1575	0.1823	0.53%	2.85E-05		0.62%	10.70%	P
6	0.0107	0.041	0.04%	2.24E-07		0.14%	1.30%	P
7	0.0628	0.0783	0.21%	4.55E-06		0.27%	7.20%	P
8	0.0177	0.0322	0.06%	3.73E-07		0.11%	1.00%	P
9	0.0167	0.0283	0.06%	3.30E-07		0.10%	3.80%	P
10	0.019	0.0347	0.06%	4.25E-07		0.12%	0.80%	P
11	0.0556	0.065	0.19%	3.56E-06		0.22%	3.10%	P
12	0.0127	0.0281	0.04%	2.06E-07		0.10%	0.70%	P
13	0.0349	0.0567	0.12%	1.44E-06		0.19%	2.00%	P
14	0.0087	0.0203	0.03%	1.04E-07	1.46E-06	0.07%	Inf%	N/A
15	0.0127	0.0229	0.04%	1.90E-07	2.86E-06	0.08%	Inf%	N/A
16	0.0135	0.0239	0.05%	2.15E-07	3.44E-06	0.08%	Inf%	N/A
17	0.0353	0.0432	0.12%	1.44E-06	2.44E-05	0.15%	Inf%	N/A
18	0.0126	0.0211	0.04%	1.91E-07	3.44E-06	0.07%	Inf%	N/A
19	0.0284	0.0471	0.10%	9.48E-07	1.80E-05	0.16%	Inf%	N/A
20	0.0056	0.0157	0.02%	4.16E-08	8.32E-07	0.05%	Inf%	N/A
21	0.0101	0.0171	0.03%	1.22E-07	2.56E-06	0.06%	Inf%	N/A
22	0.0075	0.0153	0.03%	7.35E-08	1.62E-06	0.05%	Inf%	N/A
23	0.0233	0.0295	0.08%	6.33E-07	1.46E-05	0.10%	Inf%	N/A
24	0.0096	0.0185	0.03%	1.09E-07	2.62E-06	0.06%	Inf%	N/A
25	0.0239	0.0378	0.08%	6.73E-07	1.68E-05	0.13%	Inf%	N/A
26	0.0045	0.0131	0.02%	2.85E-08	7.42E-07	0.04%	Inf%	N/A
27	0.01	0.0183	0.03%	1.26E-07	3.40E-06	0.06%	Inf%	N/A
28	0.0046	0.0123	0.02%	2.91E-08	8.14E-07	0.04%	Inf%	N/A
29	0.017	0.0226	0.06%	3.37E-07	9.77E-06	0.08%	Inf%	N/A
30	0.0063	0.0112	0.02%	4.71E-08	1.41E-06	0.04%	Inf%	N/A
31	0.02	0.0313	0.07%	4.75E-07	1.47E-05	0.11%	Inf%	N/A
32	0.0038	0.0094	0.01%	1.94E-08	6.20E-07	0.03%	Inf%	N/A
33	0.0098	0.0189	0.03%	1.18E-07	3.90E-06	0.06%	Inf%	N/A
34	0.0035	0.0099	0.01%	1.64E-08	5.57E-07	0.03%	Inf%	N/A
35	0.0112	0.0166	0.04%	1.47E-07	5.16E-06	0.06%	Inf%	N/A
36	0.0045	0.011	0.02%	2.52E-08	9.08E-07	0.04%	Inf%	N/A
37	0.016	0.0224	0.05%	3.00E-07	1.11E-05	0.08%	Inf%	N/A
38	0.0034	0.0099	0.01%	1.46E-08	5.57E-07	0.03%	Inf%	N/A
39	0.0102	0.0169	0.03%	1.22E-07	4.77E-06	0.06%	Inf%	N/A
40	0.0027	0.0094	0.01%	9.84E-09	3.94E-07	0.03%	Inf%	N/A
THD(%)				0.80%			23.00%	P
PWHD(%)					1.20%		23.00%	P

Beschreibung der Erzeugungseinheit

Hersteller	FRONIUS International GmbH Güter Fronius Straße 1 4600 Wels-Thalheim AUSTRIA	
Typ Erzeugungseinheit	Netzgekoppelter Photovoltaikwechselrichter	
Bemessungswerte	SYMO 10.0-3-M	SYMO 12.5-3-M
Nennwirkleistung	10000 W	12500 W
Nennscheinleistung	10000 VA	12500 VA
Bemessungsspannung	3/N/PE AC 400/230 V	
Firmware Version	SW1: V 0.9.8.3 ; SW2: V 0.6.10.1;	
Messzeitraum	17.02.2014 bis 28.02.2014	

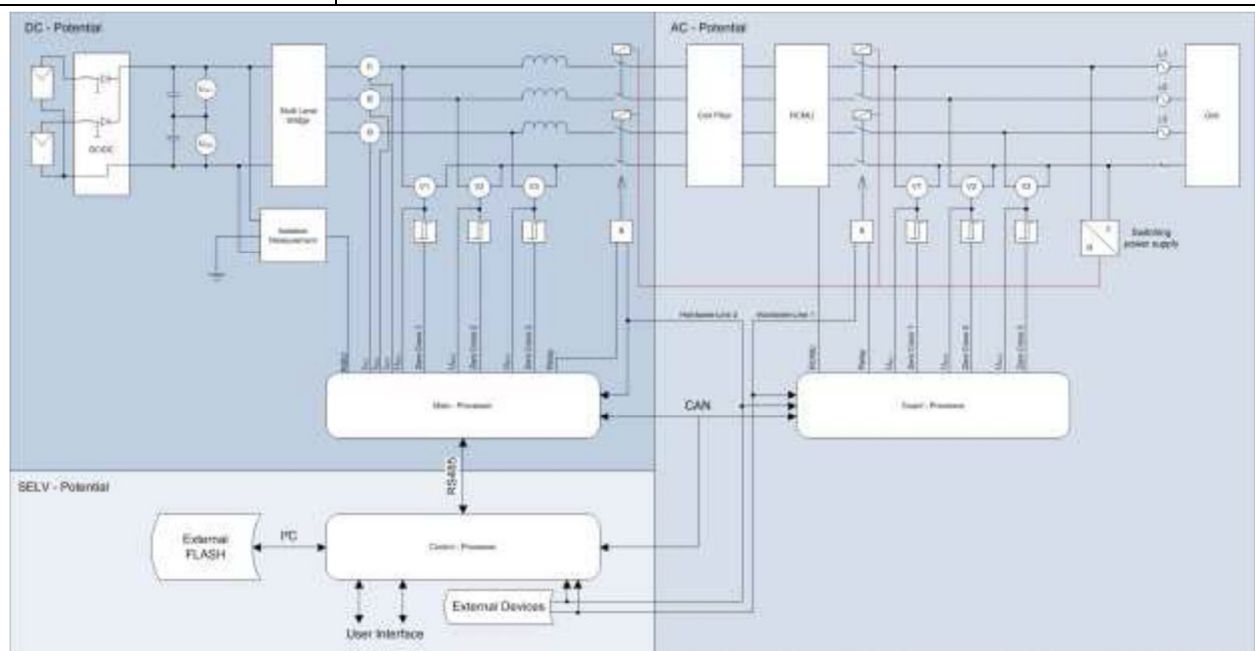
Schematischer Aufbau der Erzeugungseinheit (EZE)

Die Modelle **Fronius SYMO 10.0-3-M**, **SYMO 12.5-3-M** sind bezüglich des Erzeugungs- und Einspeiseverhaltens identisch aufgebaut und bilden die Hardware-Variante 1 (Hardware version 1 – small unit). Sie unterscheiden sich nur in der Softwarebegrenzung der maximalen Wirkleistung.

Die Prüfungen wurden am Typ **Fronius SYMO 12.5-3-M** durchgeführt und sind stellvertretend für die Geräte **Fronius SYMO 10.0-3-M, SYMO 12.5-3-M** gültig.

Wirkleistung; DIN VDE V 0124-100:2012-07; 5.3.2.1

Maximale Wirkleistung $P_{E_{max}}$	-12,884 kW
Maximale Scheinleistung $S_{E_{max}}$	12,913 kVA

Blindleistungsbezug; DIN VDE V 0124-100:2012-07; 5.3.2.1

Wirkleistung P / P _n [%]	10	20	30	40	50	60	70	80	90	100
Maximale möglicher $\cos \varphi$ untererregt	N/A	N/A	N/A	N/A	N/A	N/A	N/A	N/A	N/A	-0,896
Maximale möglicher $\cos \varphi$ übererregt	N/A	N/A	N/A	N/A	N/A	N/A	N/A	N/A	N/A	-0,904

Einhaltung eines fest vorgegeben Verschiebungsfaktor $\cos \varphi$ DIN VDE V 0124-100:2012-07; 5.3.6.1

Vorgabe in der Anlagesteuerung	-0,900 _{üb}	-0,950 _{üb}	-1,000	-0,950 _{un}	-0,900 _{un}
Messwert an den Klemmen der EZE	N/A	-0,954	N/A	-0,945	N/A

Blindleistungsübergangsfunktion – Standard- $\cos \varphi$ (P)-Kennlinie; DIN VDE V 0124-100:2012-07; 5.3.6.4

Wirkleistung P / P _n [%]	10	20	30	40	50	60	70	80	90	100*)
$\cos \varphi$	-1,000	-1,000	-1,000	-1,000	-0,999	-0,989	-0,978	-0,967	-0,958	-0,951

Die Standard- $\cos \varphi$ -(P)-Kennlinie wird eingehalten

*) Wird nicht erreicht da $S_{E_{max}} = 12,5$ kVA

Schalthandlungen; Schnelle Spannungsänderungen; DIN VDE V 0124-100:2012-07; 5.1.2

Einschalten ohne Vorgabe (zum Primärenergieträgers)	k_i	0,39
Ungünstigster Fall	k_i	1,04
Einschalten bei Nennbedingungen (des Primärenergie-trägers)	k_i	0,94
Ausschalten bei Nennleistung	k_i	0,94
Schlechtester Wert aller Schaltvorgänge	k_{imax}	1,04
Flicker (worst case)	Netzimpedanzwinkel ψ_k :	32°
	Anlagenflickerbeiwert c_{ψ} :	11,21

Oberschwingungsmessungen (Harmonics) nach EN 61000-3-12 und VDE-AR-N 4105:2011-08 Anhang F.3 (Phase L1);								
Harmonic Order	I _H _{mean}	I _H _{max}	I _H _{mean}	(Average/Ref Fund) ²	n*(Average/Ref Fund) ²	I _H _{max}	Stage 1 Limit (EN 61000-3-12)	PASS/F AIL
	(A)	(A)	(%H01)			(%H01)	∏	∏
1	18.654	18.714	100.00%			100.00%	Inf%	N/A
2	0.0394	0.1255	0.21%	5.72E-06		0.67%	4.00%	P
3	0.0458	0.0737	0.25%	6.13E-06		0.39%	21.60%	P
4	0.0241	0.0484	0.13%	1.79E-06		0.26%	2.00%	P
5	0.1399	0.1545	0.75%	5.63E-05		0.83%	10.70%	P
6	0.023	0.0357	0.12%	1.54E-06		0.19%	1.30%	P
7	0.0425	0.0574	0.23%	5.24E-06		0.31%	7.20%	P
8	0.0127	0.0191	0.07%	4.70E-07		0.10%	1.00%	P
9	0.0121	0.0188	0.07%	4.31E-07		0.10%	3.80%	P
10	0.0104	0.0171	0.06%	3.17E-07		0.09%	0.80%	P
11	0.0432	0.0524	0.23%	5.38E-06		0.28%	3.10%	P
12	0.0035	0.0147	0.02%	5.95E-08		0.08%	0.70%	P
13	0.0304	0.0445	0.16%	2.68E-06		0.24%	2.00%	P
14	0.0047	0.0101	0.03%	7.06E-08	9.89E-07	0.05%	Inf%	N/A
15	0.0076	0.0129	0.04%	1.73E-07	2.59E-06	0.07%	Inf%	N/A
16	0.009	0.0135	0.05%	2.36E-07	3.78E-06	0.07%	Inf%	N/A
17	0.0313	0.0371	0.17%	2.82E-06	4.80E-05	0.20%	Inf%	N/A
18	0.011	0.0169	0.06%	3.55E-07	6.39E-06	0.09%	Inf%	N/A
19	0.028	0.035	0.15%	2.28E-06	4.33E-05	0.19%	Inf%	N/A
20	0.0106	0.0177	0.06%	3.29E-07	6.58E-06	0.10%	Inf%	N/A
21	0.0127	0.0178	0.07%	4.70E-07	9.87E-06	0.10%	Inf%	N/A
22	0.0088	0.0135	0.05%	2.27E-07	4.98E-06	0.07%	Inf%	N/A
23	0.0067	0.0123	0.04%	1.35E-07	3.10E-06	0.07%	Inf%	N/A
24	0.0041	0.0096	0.02%	5.27E-08	1.26E-06	0.05%	Inf%	N/A
25	0.0153	0.0185	0.08%	6.84E-07	1.71E-05	0.10%	Inf%	N/A
26	0.0027	0.0087	0.02%	2.57E-08	6.69E-07	0.05%	Inf%	N/A
27	0.0053	0.0082	0.03%	8.19E-08	2.21E-06	0.04%	Inf%	N/A
28	0.0039	0.0072	0.02%	4.70E-08	1.32E-06	0.04%	Inf%	N/A
29	0.0039	0.011	0.02%	5.16E-08	1.50E-06	0.06%	Inf%	N/A
30	0.0029	0.0059	0.02%	2.63E-08	7.90E-07	0.03%	Inf%	N/A
31	0.0113	0.0147	0.06%	3.79E-07	1.18E-05	0.08%	Inf%	N/A
32	0.0061	0.0089	0.03%	1.10E-07	3.51E-06	0.05%	Inf%	N/A
33	0.0049	0.0087	0.03%	7.34E-08	2.42E-06	0.05%	Inf%	N/A
34	0.0027	0.0055	0.02%	2.30E-08	7.81E-07	0.03%	Inf%	N/A
35	0.0041	0.0106	0.02%	5.24E-08	1.84E-06	0.06%	Inf%	N/A
36	0.0039	0.0075	0.02%	4.55E-08	1.64E-06	0.04%	Inf%	N/A
37	0.0075	0.0101	0.04%	1.64E-07	6.05E-06	0.05%	Inf%	N/A
38	0.0031	0.0056	0.02%	2.89E-08	1.10E-06	0.03%	Inf%	N/A
39	0.0049	0.0088	0.03%	7.20E-08	2.81E-06	0.05%	Inf%	N/A
40	0.0021	0.0052	0.01%	1.36E-08	5.43E-07	0.03%	Inf%	N/A
THD(%)				1.00%			23.00%	P
PWHD(%)					1.40%		23.00%	P

Oberschwingungsmessungen (Harmonics) nach EN 61000-3-12 und VDE-AR-N 4105:2011-08 Anhang F.3 (Phase L2);								
Harmonic Order	I _H _{mean}	I _H _{max}	I _H _{mean}	(Average/Ref Fund) ²	n*(Average/Ref Fund) ²	I _H _{max}	Stage 1 Limit (EN 61000-3-12)	PASS/FAIL
	(A)	(A)	(%H01)			(%H01)	[]	[]
1	18.4459	18.5127	100.00%		[]	100.00%	Inf%	N/A
2	0.032	0.1641	0.17%	7.82E-06	[]	0.89%	4.00%	P
3	0.0951	0.1293	0.52%	2.69E-05	[]	0.70%	21.60%	P
4	0.0268	0.0778	0.15%	2.65E-06	[]	0.42%	2.00%	P
5	0.1955	0.2218	1.06%	1.13E-04	[]	1.20%	10.70%	P
6	0.0263	0.0495	0.14%	2.15E-06	[]	0.27%	1.30%	P
7	0.034	0.0634	0.18%	3.59E-06	[]	0.34%	7.20%	P
8	0.0178	0.0346	0.10%	9.79E-07	[]	0.19%	1.00%	P
9	0.0743	0.0856	0.40%	1.62E-05	[]	0.46%	3.80%	P
10	0.0168	0.0292	0.09%	8.57E-07	[]	0.16%	0.80%	P
11	0.0301	0.0583	0.16%	2.80E-06	[]	0.32%	3.10%	P
12	0.0089	0.0205	0.05%	2.63E-07	[]	0.11%	0.70%	P
13	0.0802	0.0858	0.44%	1.89E-05	[]	0.47%	2.00%	P
14	0.0053	0.018	0.03%	1.12E-07	1.56E-06	0.10%	Inf%	N/A
15	0.0209	0.0308	0.11%	1.30E-06	1.95E-05	0.17%	Inf%	N/A
16	0.0049	0.0162	0.03%	9.18E-08	1.47E-06	0.09%	Inf%	N/A
17	0.0583	0.0661	0.32%	1.00E-05	1.70E-04	0.36%	Inf%	N/A
18	0.0079	0.018	0.04%	1.98E-07	3.56E-06	0.10%	Inf%	N/A
19	0.013	0.0236	0.07%	5.18E-07	9.85E-06	0.13%	Inf%	N/A
20	0.0096	0.0188	0.05%	2.81E-07	5.61E-06	0.10%	Inf%	N/A
21	0.0314	0.0373	0.17%	2.91E-06	6.12E-05	0.20%	Inf%	N/A
22	0.0095	0.016	0.05%	2.72E-07	5.98E-06	0.09%	Inf%	N/A
23	0.0125	0.0198	0.07%	4.78E-07	1.10E-05	0.11%	Inf%	N/A
24	0.0065	0.0127	0.04%	1.29E-07	3.09E-06	0.07%	Inf%	N/A
25	0.031	0.0348	0.17%	2.86E-06	7.15E-05	0.19%	Inf%	N/A
26	0.0056	0.0128	0.03%	1.02E-07	2.65E-06	0.07%	Inf%	N/A
27	0.0117	0.0168	0.06%	4.13E-07	1.11E-05	0.09%	Inf%	N/A
28	0.0025	0.0093	0.01%	2.59E-08	7.26E-07	0.05%	Inf%	N/A
29	0.0154	0.0185	0.08%	7.01E-07	2.03E-05	0.10%	Inf%	N/A
30	0.0028	0.0093	0.02%	3.10E-08	9.29E-07	0.05%	Inf%	N/A
31	0.0174	0.0211	0.09%	8.93E-07	2.77E-05	0.11%	Inf%	N/A
32	0.0043	0.0105	0.02%	5.87E-08	1.88E-06	0.06%	Inf%	N/A
33	0.0083	0.013	0.05%	2.12E-07	6.98E-06	0.07%	Inf%	N/A
34	0.0023	0.0082	0.01%	2.04E-08	6.94E-07	0.05%	Inf%	N/A
35	0.0163	0.0195	0.09%	7.89E-07	2.76E-05	0.11%	Inf%	N/A
36	0.0038	0.0088	0.02%	4.72E-08	1.70E-06	0.05%	Inf%	N/A
37	0.0103	0.0176	0.06%	3.20E-07	1.18E-05	0.10%	Inf%	N/A
38	0.003	0.0075	0.02%	2.95E-08	1.12E-06	0.04%	Inf%	N/A
39	0.0106	0.0148	0.06%	3.36E-07	1.31E-05	0.08%	Inf%	N/A
40	0.0031	0.0078	0.02%	3.22E-08	1.29E-06	0.04%	Inf%	N/A
THD(%)				1.50%			23.00%	P
PWHD(%)					2.20%		23.00%	P

Oberschwingungsmessungen (Harmonics) nach EN 61000-3-12 und VDE-AR-N 4105:2011-08 Anhang F.3 (Phase L3);								
Harmonic Order	I _H _{mean}	I _H _{max}	I _H _{mean}	(Average/Ref Fund) ²	n*(Average/Ref Fund) ²	I _H _{max}	Stage 1 Limit (EN 61000-3-12)	PASS/FAIL
	(A)	(A)	(%H01)			(%H01)	∞	∞
1	18.6512	18.7265	100.00%		∞	100.00%	Inf%	N/A
2	0.0326	0.1341	0.17%	5.52E-06	∞	0.72%	4.00%	P
3	0.0342	0.0887	0.18%	3.78E-06	∞	0.47%	21.60%	P
4	0.01	0.0561	0.05%	7.48E-07	∞	0.30%	2.00%	P
5	0.1115	0.1332	0.60%	3.58E-05	∞	0.71%	10.70%	P
6	0.0066	0.0299	0.04%	2.40E-07	∞	0.16%	1.30%	P
7	0.0743	0.0843	0.40%	1.59E-05	∞	0.45%	7.20%	P
8	0.0069	0.0229	0.04%	1.85E-07	∞	0.12%	1.00%	P
9	0.0149	0.0266	0.08%	6.57E-07	∞	0.14%	3.80%	P
10	0.0076	0.0202	0.04%	1.95E-07	∞	0.11%	0.80%	P
11	0.0335	0.0463	0.18%	3.26E-06	∞	0.25%	3.10%	P
12	0.0079	0.0156	0.04%	1.90E-07	∞	0.08%	0.70%	P
13	0.0258	0.0326	0.14%	1.93E-06	∞	0.17%	2.00%	P
14	0.0078	0.0159	0.04%	1.87E-07	2.62E-06	0.09%	Inf%	N/A
15	0.012	0.0194	0.06%	4.20E-07	6.30E-06	0.10%	Inf%	N/A
16	0.0065	0.0148	0.04%	1.32E-07	2.11E-06	0.08%	Inf%	N/A
17	0.0274	0.034	0.15%	2.18E-06	3.70E-05	0.18%	Inf%	N/A
18	0.0045	0.0111	0.02%	6.44E-08	1.16E-06	0.06%	Inf%	N/A
19	0.0223	0.0266	0.12%	1.44E-06	2.73E-05	0.14%	Inf%	N/A
20	0.0031	0.0105	0.02%	3.80E-08	7.60E-07	0.06%	Inf%	N/A
21	0.0084	0.0135	0.05%	2.07E-07	4.34E-06	0.07%	Inf%	N/A
22	0.0026	0.0091	0.01%	2.62E-08	5.76E-07	0.05%	Inf%	N/A
23	0.018	0.0216	0.10%	9.40E-07	2.16E-05	0.12%	Inf%	N/A
24	0.0034	0.0091	0.02%	3.91E-08	9.38E-07	0.05%	Inf%	N/A
25	0.0132	0.018	0.07%	5.03E-07	1.26E-05	0.10%	Inf%	N/A
26	0.004	0.0088	0.02%	4.94E-08	1.28E-06	0.05%	Inf%	N/A
27	0.0081	0.0123	0.04%	1.91E-07	5.16E-06	0.07%	Inf%	N/A
28	0.0042	0.0083	0.02%	5.30E-08	1.49E-06	0.05%	Inf%	N/A
29	0.0143	0.0176	0.08%	6.00E-07	1.74E-05	0.09%	Inf%	N/A
30	0.0041	0.0084	0.02%	5.09E-08	1.53E-06	0.05%	Inf%	N/A
31	0.0041	0.0148	0.02%	6.54E-08	2.03E-06	0.08%	Inf%	N/A
32	0.0031	0.0068	0.02%	2.91E-08	9.30E-07	0.04%	Inf%	N/A
33	0.007	0.01	0.04%	1.42E-07	4.68E-06	0.05%	Inf%	N/A
34	0.0026	0.0068	0.01%	2.26E-08	7.67E-07	0.04%	Inf%	N/A
35	0.0103	0.0128	0.06%	3.07E-07	1.08E-05	0.07%	Inf%	N/A
36	0.0018	0.0054	0.01%	1.16E-08	4.18E-07	0.03%	Inf%	N/A
37	0.0053	0.0128	0.03%	8.91E-08	3.30E-06	0.07%	Inf%	N/A
38	0.0019	0.0054	0.01%	1.21E-08	4.60E-07	0.03%	Inf%	N/A
39	0.0053	0.0079	0.03%	8.24E-08	3.21E-06	0.04%	Inf%	N/A
40	0.0022	0.006	0.01%	1.56E-08	6.25E-07	0.03%	Inf%	N/A
THD(%)				0.90%			23.00%	P
PWHD(%)					1.30%		23.00%	P

Oberschwingungen bis 2 kHz											
Maximale Mittelwerte der harmonischen Ströme bezogen auf den Nennstrom der EZE											
Pbin (%)	0	10	20	30	40	50	60	70	80	90	100
Nr./ Order	Ih/In (%)	Ih/In (%)	Ih/In (%)	Ih/In (%)	Ih/In (%)	Ih/In (%)	Ih/In (%)	Ih/In (%)	Ih/In (%)	Ih/In (%)	Ih/In (%)
2	0.00%	0.07%	0.08%	0.10%	0.10%	0.09%	0.12%	0.13%	0.14%	0.16%	0.18%
3	0.11%	0.16%	0.18%	0.20%	0.20%	0.22%	0.23%	0.25%	0.28%	0.31%	0.35%
4	0.00%	0.03%	0.03%	0.04%	0.04%	0.04%	0.05%	0.05%	0.06%	0.06%	0.06%
5	0.10%	0.18%	0.27%	0.41%	0.41%	0.44%	0.47%	0.49%	0.52%	0.55%	0.53%
6	0.00%	0.02%	0.02%	0.02%	0.02%	0.03%	0.03%	0.03%	0.03%	0.03%	0.04%
7	0.10%	0.21%	0.24%	0.15%	0.15%	0.17%	0.18%	0.19%	0.19%	0.20%	0.19%
8	0.00%	0.02%	0.02%	0.02%	0.02%	0.02%	0.02%	0.03%	0.03%	0.03%	0.03%
9	0.09%	0.12%	0.12%	0.14%	0.14%	0.15%	0.16%	0.17%	0.18%	0.20%	0.20%
10	0.00%	0.01%	0.01%	0.02%	0.02%	0.02%	0.02%	0.02%	0.02%	0.02%	0.02%
11	0.09%	0.20%	0.18%	0.16%	0.16%	0.14%	0.12%	0.13%	0.13%	0.15%	0.10%
12	0.00%	0.01%	0.01%	0.01%	0.01%	0.02%	0.02%	0.02%	0.02%	0.02%	0.02%
13	0.08%	0.08%	0.12%	0.18%	0.18%	0.21%	0.22%	0.23%	0.25%	0.26%	0.27%
14	0.00%	0.01%	0.01%	0.01%	0.01%	0.01%	0.01%	0.01%	0.02%	0.02%	0.02%
15	0.07%	0.09%	0.09%	0.09%	0.09%	0.09%	0.09%	0.09%	0.08%	0.08%	0.09%
16	0.00%	0.01%	0.01%	0.01%	0.01%	0.01%	0.01%	0.01%	0.02%	0.02%	0.02%
17	0.06%	0.07%	0.08%	0.12%	0.12%	0.14%	0.16%	0.18%	0.19%	0.20%	0.20%
18	0.00%	0.01%	0.01%	0.01%	0.01%	0.01%	0.01%	0.01%	0.01%	0.02%	0.02%
19	0.05%	0.07%	0.07%	0.07%	0.07%	0.06%	0.07%	0.08%	0.08%	0.08%	0.08%
20	0.00%	0.01%	0.01%	0.01%	0.01%	0.01%	0.01%	0.01%	0.01%	0.01%	0.02%
21	0.05%	0.06%	0.06%	0.07%	0.07%	0.08%	0.08%	0.09%	0.09%	0.10%	0.10%
22	0.00%	0.01%	0.01%	0.01%	0.01%	0.01%	0.01%	0.01%	0.01%	0.01%	0.01%
23	0.04%	0.04%	0.04%	0.04%	0.04%	0.05%	0.05%	0.06%	0.07%	0.07%	0.07%
24	0.00%	0.01%	0.01%	0.01%	0.01%	0.01%	0.01%	0.01%	0.01%	0.01%	0.02%
25	0.03%	0.04%	0.05%	0.07%	0.07%	0.07%	0.09%	0.10%	0.10%	0.11%	0.11%
26	0.00%	0.01%	0.01%	0.01%	0.01%	0.01%	0.01%	0.01%	0.01%	0.01%	0.01%
27	0.02%	0.01%	0.01%	0.02%	0.02%	0.02%	0.02%	0.03%	0.04%	0.05%	0.06%
28	0.00%	0.01%	0.01%	0.01%	0.01%	0.01%	0.01%	0.01%	0.01%	0.01%	0.02%
29	0.02%	0.03%	0.02%	0.03%	0.03%	0.04%	0.05%	0.06%	0.07%	0.08%	0.09%
30	0.00%	0.01%	0.01%	0.01%	0.01%	0.01%	0.01%	0.01%	0.01%	0.01%	0.02%
31	0.01%	0.02%	0.03%	0.04%	0.04%	0.04%	0.05%	0.07%	0.07%	0.08%	0.09%
32	0.00%	0.01%	0.01%	0.01%	0.01%	0.01%	0.01%	0.01%	0.01%	0.02%	0.02%
33	0.01%	0.01%	0.01%	0.02%	0.02%	0.02%	0.02%	0.03%	0.04%	0.04%	0.05%
34	0.00%	0.02%	0.02%	0.01%	0.01%	0.01%	0.01%	0.01%	0.01%	0.01%	0.02%
35	0.01%	0.02%	0.03%	0.04%	0.04%	0.04%	0.05%	0.06%	0.08%	0.09%	0.10%
36	0.00%	0.02%	0.02%	0.01%	0.01%	0.01%	0.01%	0.01%	0.01%	0.01%	0.02%
37	0.01%	0.01%	0.02%	0.02%	0.02%	0.03%	0.03%	0.04%	0.05%	0.06%	0.07%
38	0.00%	0.02%	0.02%	0.01%	0.01%	0.01%	0.01%	0.01%	0.01%	0.01%	0.02%
39	0.01%	0.02%	0.02%	0.03%	0.03%	0.04%	0.04%	0.05%	0.06%	0.06%	0.08%
40	0.00%	0.02%	0.02%	0.02%	0.02%	0.01%	0.01%	0.01%	0.01%	0.01%	0.02%
41	0.01%	0.03%	0.02%	0.03%	0.03%	0.04%	0.04%	0.05%	0.06%	0.07%	0.09%
42	0.00%	0.02%	0.02%	0.02%	0.02%	0.02%	0.01%	0.01%	0.01%	0.01%	0.02%
43	0.01%	0.03%	0.03%	0.03%	0.03%	0.04%	0.04%	0.05%	0.05%	0.06%	0.07%

Oberschwingungen bis 2 kHz											
Maximale Mittelwerte der harmonischen Ströme bezogen auf den Nennstrom der EZE											
Pbin (%)	0	10	20	30	40	50	60	70	80	90	100
Nr./ Order	Ih/In (%)	Ih/In (%)	Ih/In (%)	Ih/In (%)	Ih/In (%)	Ih/In (%)	Ih/In (%)	Ih/In (%)	Ih/In (%)	Ih/In (%)	Ih/In (%)
44	0.00%	0.02%	0.02%	0.02%	0.02%	0.02%	0.02%	0.02%	0.02%	0.02%	0.02%
45	0.01%	0.02%	0.03%	0.03%	0.03%	0.04%	0.05%	0.05%	0.06%	0.07%	0.09%
46	0.00%	0.02%	0.02%	0.02%	0.02%	0.02%	0.02%	0.01%	0.01%	0.01%	0.02%
47	0.01%	0.03%	0.03%	0.04%	0.04%	0.04%	0.05%	0.05%	0.06%	0.07%	0.09%
48	0.00%	0.02%	0.02%	0.02%	0.02%	0.02%	0.01%	0.01%	0.01%	0.01%	0.02%
49	0.01%	0.04%	0.04%	0.04%	0.04%	0.04%	0.05%	0.05%	0.06%	0.06%	0.08%
50	0.00%	0.02%	0.02%	0.02%	0.02%	0.02%	0.02%	0.02%	0.02%	0.02%	0.02%
THC (%)	0.27%	0.45%	0.52%	0.61%	0.61%	0.66%	0.70%	0.75%	0.80%	0.86%	0.88%

Zwischenharmonische											
Maximale Mittelwerte der zwischenharmonischen Ströme bezogen auf den Nennstrom der EZE											
P_{bin} (%)	0	10	20	30	40	50	60	70	80	90	100
f (Hz)	lh/ln (%)	lh/ln (%)	lh/ln (%)	lh/ln (%)	lh/ln (%)	lh/ln (%)	lh/ln (%)	lh/ln (%)	lh/ln (%)	lh/ln (%)	lh/ln (%)
75	0.01%	0.17%	0.21%	0.26%	0.26%	0.30%	0.34%	0.38%	0.42%	0.46%	0.47%
125	0.01%	0.07%	0.08%	0.10%	0.10%	0.12%	0.12%	0.14%	0.15%	0.16%	0.15%
175	0.01%	0.06%	0.06%	0.08%	0.08%	0.09%	0.09%	0.10%	0.11%	0.12%	0.11%
225	0.00%	0.03%	0.04%	0.05%	0.05%	0.06%	0.06%	0.07%	0.07%	0.08%	0.07%
275	0.00%	0.03%	0.04%	0.04%	0.04%	0.05%	0.05%	0.06%	0.06%	0.06%	0.06%
325	0.00%	0.03%	0.03%	0.04%	0.04%	0.04%	0.04%	0.05%	0.05%	0.05%	0.05%
375	0.00%	0.02%	0.02%	0.03%	0.03%	0.03%	0.03%	0.03%	0.04%	0.04%	0.04%
425	0.00%	0.02%	0.02%	0.03%	0.03%	0.03%	0.03%	0.04%	0.04%	0.04%	0.04%
475	0.00%	0.02%	0.02%	0.03%	0.03%	0.03%	0.03%	0.03%	0.04%	0.04%	0.03%
525	0.00%	0.01%	0.02%	0.02%	0.02%	0.02%	0.03%	0.03%	0.03%	0.04%	0.03%
575	0.00%	0.01%	0.02%	0.02%	0.02%	0.02%	0.02%	0.03%	0.03%	0.03%	0.03%
625	0.00%	0.01%	0.01%	0.02%	0.02%	0.02%	0.02%	0.03%	0.03%	0.03%	0.03%
675	0.00%	0.01%	0.01%	0.02%	0.02%	0.02%	0.02%	0.02%	0.02%	0.03%	0.03%
725	0.00%	0.01%	0.01%	0.02%	0.02%	0.02%	0.02%	0.02%	0.02%	0.03%	0.03%
775	0.00%	0.01%	0.01%	0.02%	0.02%	0.02%	0.02%	0.02%	0.02%	0.02%	0.02%
825	0.00%	0.01%	0.01%	0.01%	0.01%	0.02%	0.02%	0.02%	0.02%	0.02%	0.02%
875	0.00%	0.01%	0.01%	0.01%	0.01%	0.02%	0.02%	0.02%	0.02%	0.02%	0.02%
925	0.00%	0.01%	0.01%	0.01%	0.01%	0.02%	0.02%	0.02%	0.02%	0.02%	0.02%
975	0.00%	0.01%	0.01%	0.01%	0.01%	0.02%	0.02%	0.02%	0.02%	0.02%	0.02%
1025	0.00%	0.01%	0.01%	0.01%	0.01%	0.02%	0.02%	0.02%	0.02%	0.02%	0.02%
1075	0.00%	0.01%	0.01%	0.01%	0.01%	0.01%	0.01%	0.02%	0.02%	0.02%	0.02%
1125	0.00%	0.01%	0.01%	0.01%	0.01%	0.01%	0.02%	0.02%	0.02%	0.02%	0.02%
1175	0.00%	0.01%	0.01%	0.01%	0.01%	0.01%	0.01%	0.02%	0.02%	0.02%	0.02%
1225	0.00%	0.01%	0.01%	0.01%	0.01%	0.01%	0.01%	0.02%	0.02%	0.02%	0.02%
1275	0.00%	0.01%	0.01%	0.01%	0.01%	0.01%	0.01%	0.02%	0.02%	0.02%	0.02%
1325	0.00%	0.01%	0.01%	0.01%	0.01%	0.01%	0.01%	0.02%	0.02%	0.02%	0.02%
1375	0.00%	0.01%	0.01%	0.01%	0.01%	0.01%	0.01%	0.01%	0.02%	0.02%	0.01%
1425	0.00%	0.01%	0.01%	0.01%	0.01%	0.01%	0.01%	0.02%	0.02%	0.02%	0.01%
1475	0.00%	0.01%	0.01%	0.01%	0.01%	0.01%	0.01%	0.01%	0.02%	0.02%	0.01%
1525	0.00%	0.01%	0.01%	0.01%	0.01%	0.01%	0.01%	0.01%	0.02%	0.02%	0.01%
1575	0.00%	0.01%	0.01%	0.01%	0.01%	0.01%	0.01%	0.01%	0.02%	0.02%	0.01%
1625	0.00%	0.01%	0.01%	0.01%	0.01%	0.01%	0.01%	0.01%	0.02%	0.02%	0.01%
1675	0.00%	0.01%	0.01%	0.01%	0.01%	0.01%	0.01%	0.01%	0.01%	0.02%	0.01%
1725	0.00%	0.01%	0.01%	0.01%	0.01%	0.01%	0.01%	0.01%	0.01%	0.02%	0.01%
1775	0.00%	0.01%	0.01%	0.01%	0.01%	0.01%	0.01%	0.01%	0.01%	0.02%	0.01%
1825	0.00%	0.01%	0.01%	0.01%	0.01%	0.01%	0.01%	0.01%	0.01%	0.02%	0.01%
1875	0.00%	0.01%	0.01%	0.01%	0.01%	0.01%	0.01%	0.01%	0.01%	0.02%	0.01%
1925	0.00%	0.01%	0.01%	0.01%	0.01%	0.01%	0.01%	0.01%	0.01%	0.02%	0.01%
1975	0.00%	0.01%	0.01%	0.01%	0.01%	0.01%	0.01%	0.01%	0.01%	0.02%	0.01%

Höhere Frequenzen											
Maximale Mittelwerte der Ströme im Frequenzbereich von 2 kHz bis 9 kHz bezogen auf den Nennstrom der EZE.											
P _{bin} (%)	0	10	20	30	40	50	60	70	80	90	100
f (kHz)	I _h /I _n (%)	I _n /I _n (%)	I _h /I _n (%)	I _h /I _n (%)	I _n /I _n (%)	I _h /I _n (%)	I _h /I _n (%)	I _h /I _n (%)	I _h /I _n (%)	I _h /I _n (%)	I _h /I _n (%)
2.1	0.02%	0.05%	0.05%	0.06%	0.06%	0.06%	0.07%	0.08%	0.09%	0.10%	0.12%
2.3	0.02%	0.05%	0.05%	0.06%	0.06%	0.07%	0.08%	0.08%	0.09%	0.11%	0.13%
2.5	0.01%	0.06%	0.06%	0.06%	0.06%	0.07%	0.08%	0.08%	0.09%	0.10%	0.13%
2.7	0.01%	0.06%	0.06%	0.07%	0.07%	0.07%	0.08%	0.09%	0.09%	0.10%	0.12%
2.9	0.01%	0.06%	0.06%	0.07%	0.07%	0.08%	0.08%	0.09%	0.10%	0.10%	0.12%
3.1	0.01%	0.06%	0.06%	0.07%	0.07%	0.07%	0.08%	0.09%	0.09%	0.10%	0.12%
3.3	0.01%	0.06%	0.07%	0.07%	0.07%	0.07%	0.08%	0.08%	0.09%	0.09%	0.11%
3.5	0.01%	0.05%	0.06%	0.07%	0.07%	0.07%	0.08%	0.08%	0.09%	0.09%	0.10%
3.7	0.01%	0.05%	0.06%	0.07%	0.07%	0.07%	0.07%	0.08%	0.08%	0.09%	0.10%
3.9	0.01%	0.05%	0.06%	0.07%	0.07%	0.07%	0.07%	0.07%	0.08%	0.08%	0.09%
4.1	0.01%	0.05%	0.05%	0.06%	0.06%	0.06%	0.07%	0.07%	0.07%	0.07%	0.08%
4.3	0.01%	0.04%	0.04%	0.05%	0.05%	0.06%	0.06%	0.06%	0.06%	0.07%	0.07%
4.5	0.01%	0.04%	0.04%	0.05%	0.05%	0.05%	0.05%	0.06%	0.06%	0.06%	0.06%
4.7	0.01%	0.04%	0.04%	0.05%	0.05%	0.05%	0.05%	0.05%	0.05%	0.05%	0.05%
4.9	0.01%	0.06%	0.06%	0.06%	0.06%	0.07%	0.07%	0.07%	0.07%	0.07%	0.07%
5.1	0.01%	0.06%	0.07%	0.07%	0.07%	0.07%	0.07%	0.07%	0.08%	0.08%	0.08%
5.3	0.00%	0.03%	0.03%	0.03%	0.03%	0.03%	0.03%	0.03%	0.04%	0.04%	0.04%
5.5	0.01%	0.02%	0.03%	0.03%	0.03%	0.03%	0.03%	0.03%	0.03%	0.03%	0.04%
5.7	0.01%	0.02%	0.03%	0.03%	0.03%	0.03%	0.03%	0.03%	0.04%	0.04%	0.04%
5.9	0.01%	0.02%	0.02%	0.02%	0.02%	0.03%	0.03%	0.03%	0.03%	0.04%	0.04%
6.1	0.01%	0.02%	0.03%	0.03%	0.03%	0.03%	0.03%	0.03%	0.03%	0.04%	0.04%
6.3	0.01%	0.02%	0.03%	0.03%	0.03%	0.03%	0.03%	0.03%	0.04%	0.04%	0.05%
6.5	0.01%	0.02%	0.02%	0.03%	0.03%	0.03%	0.03%	0.03%	0.04%	0.04%	0.05%
6.7	0.01%	0.03%	0.03%	0.03%	0.03%	0.03%	0.03%	0.04%	0.04%	0.04%	0.05%
6.9	0.01%	0.03%	0.03%	0.03%	0.03%	0.03%	0.03%	0.04%	0.04%	0.05%	0.05%
7.1	0.01%	0.02%	0.02%	0.03%	0.03%	0.03%	0.04%	0.04%	0.04%	0.04%	0.05%
7.3	0.01%	0.03%	0.03%	0.03%	0.03%	0.03%	0.04%	0.04%	0.04%	0.04%	0.05%
7.5	0.01%	0.03%	0.03%	0.04%	0.04%	0.04%	0.04%	0.04%	0.04%	0.04%	0.06%
7.7	0.01%	0.04%	0.03%	0.03%	0.03%	0.03%	0.03%	0.03%	0.03%	0.04%	0.04%
7.9	0.01%	0.04%	0.03%	0.03%	0.03%	0.03%	0.03%	0.04%	0.04%	0.04%	0.04%
8.1	0.01%	0.03%	0.04%	0.03%	0.03%	0.03%	0.03%	0.03%	0.03%	0.03%	0.04%
8.3	0.01%	0.03%	0.04%	0.03%	0.03%	0.03%	0.03%	0.03%	0.03%	0.03%	0.04%
8.5	0.01%	0.03%	0.04%	0.03%	0.03%	0.03%	0.03%	0.03%	0.03%	0.03%	0.03%
8.7	0.01%	0.02%	0.03%	0.02%	0.02%	0.02%	0.02%	0.02%	0.02%	0.02%	0.03%
8.9	0.01%	0.02%	0.02%	0.02%	0.02%	0.02%	0.02%	0.02%	0.02%	0.02%	0.03%